

X30 MUD/GAS SEPARATOR



FEATURES & BENEFITS

- Design for special operations
- Separates free gas including H₂S
- Reduce threats of hazardous and toxic gases
- Designed to ASME and NACE specifications
- Corrosion-resistant epoxy coated to ensure long life
- Small footprint saves space
- Vents free gas

The M-I SWACO* X30 MUD/GAS SEPARATOR* is a field proven, extremely reliable and necessary piece of safety equipment for today's drilling and workover operations.

It is ideal for use where drilling and workover activities are likely to encounter sour gas or when an operator needs to control the well with small and efficient equipment. The X30 MUD/GAS SEPARATOR is primarily used to separate and safely vent pockets of free gas, including hydrogen sulfide, that can be produced from the drilling/workover operations.

Design for special operations. The X30 MUD/GAS SEPARATOR is designed for special drilling/workover operations where small size and efficiency are a necessity; the equipment can be custom designed to accommodate the needs of special projects.

Separates free gas. Separates and vents pockets of free-gas accumulations, including toxic gases such as H₂S, from the active system.

Reduce Hazardous gas threat. The separated gas is carried by the vent line to a remote location and flared.

Manufactured to exacting standards in accordance with:

- NACE MR-01-75 for H₂S service — Provides for safe handling of corrosive, deadly sour gas and gas-cut drilling fluids.
- ASME Boiler and Pressure Vessel Code Section VIII, Division I, Section IX, Lethal Service and So Stamped — Provides maximum rigsite safety during underbalanced drilling operations.

Rugged Construction. The unit is ruggedly built and coated with corrosion-resistant epoxy to ensure long life while processing hazardous and toxic gases.

How it works

The X30 MUD/GAS SEPARATOR consists of a cylindrical pressure vessel in a fixed vertical position. Inside is a series of specially angled baffle plates, stepped from the top to the bottom. When contaminated mud is routed into the separator, it flows downward successively over each plate.

During this process, the heads of entrained gases “break out”. The released gas is then carried by the vent line to a remote location where it can be safely flared.

The U-tube height is set to maintain the optimum liquid level in the separator, ensuring adequate retention time in the separator for the gas to break out.

The M-I SWACO X30 MUD/GAS SEPARATOR is ideal to assist in controlling dangerous, near surface expansion and accumulation of gas during a well kick.

Specifications	Length	Width	Height	Weight	Footprint (Skid)
X30 MGS	108 in. (2,743 mm)	39 in. (991 mm)	114 in. (2,896 mm)	1,700 lb (771 kg)	39 x 39 in (991 X 991 mm)
Liquid Capacity		Gas Capacity		Working Pressure	
450 gpm (1.703.4L/min)		16.7 MM scf/d (471,891 m3/d)		125 psi (8.6 bar)	

Notes:

1. Manufactured in accordance with ASME Section VIII, Division I, Section IX for Lethal Service and NACE Standard MRO175 for H₂S Service (Maximum HRC 22).
2. Working Pressure: 125 PSIG (8.6 bar)
Working Temperature: -20°F (-29°C) to 350°F (177°C)
3. Finish per customer contract. If not specified finish per S.S. 103 (SWACO Orange).
4. Preservation procedure S.S. 262 (CORTEC M-645).
5. Approximate weight 1,700 lb (771 kg).
6. Internal corrosion allowance 3/16 in.

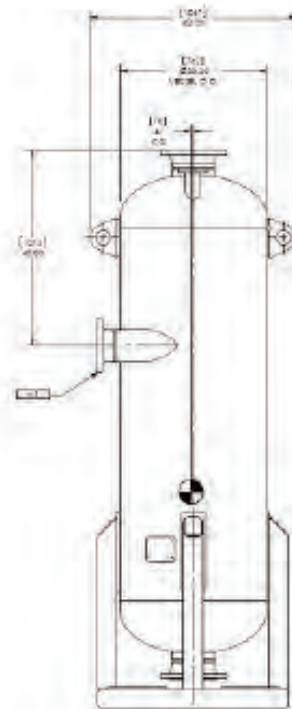
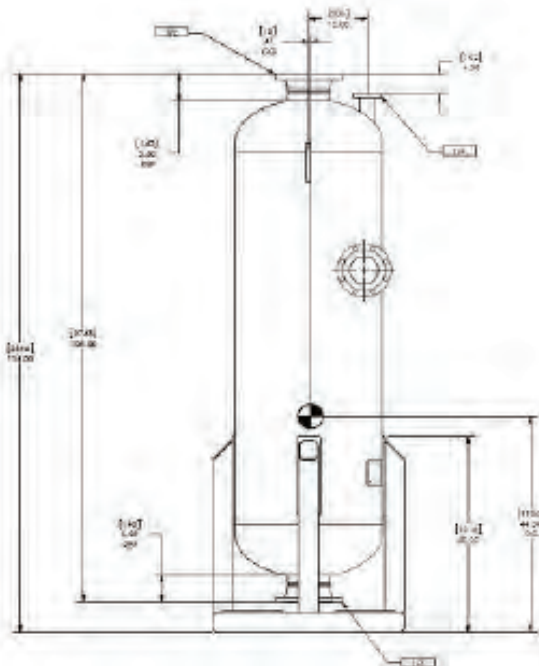
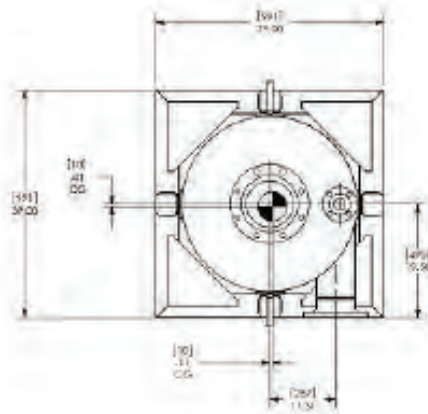

Specifications

Since each configuration is customized for a specific project, specifications vary. Contact your local M-I SWACO representative to receive additional information on how the X30 Mud/Gas Separator system can save you time and money.



P.O. Box 42842
Houston, Texas 77242-2842
Tel: 281-561-1300
Fax: 281-561-1441
www.miswaco.com
E-mail: questions@miswaco.com

This information is supplied solely for informational purposes and M-I SWACO makes no guarantees or warranties, either expressed or implied, with respect to the accuracy and use of this data. All product warranties and guarantees shall be governed by the Standard Terms of Sale. Nothing in this document is legal advice or is a substitute for competent legal advice.