

Integrating RSS, Reamer, and PDC Bit Saves 6 Days in Shallow Persian Gulf Formation

Optimized BHA system drills and underreams in hard shale formation while mitigating shock and vibration

CHALLENGE

Directionally drill and underream a 14½-in interval through interbedded layers of limestone, anhydrites, and shale in a shallow offshore formation while mitigating shock and vibration.

SOLUTION

Design a BHA system and recommend optimal drilling parameters using the i-DRILL* engineered drilling system design.

RESULT

Simultaneously drilled and underreamed the section in approximately 11 days, saving more than 6 days of rig time and approximately USD 744,000.



Drill and underream through layers of limestone, anhydrites, and shale

During development of a shallow oil field in the Persian Gulf, the operator needed to drill and underream a 14½-in section through interbedded layers of limestone, anhydrites, and shale. A conventional steerable BHA was used to drill the 14½-in section of an offset well to TD. Then a second run was performed to open the hole to 16 in. The two runs took almost 17 days to complete.

To optimize the drilling process for the second well, the operator decided to drill and underream simultaneously. The plan was to directionally drill 1,200 ft while building inclination from approximately 5° to 25° at TD and underreaming in the same run.

Design a customized BHA with RSS and hydraulically expandable reamer

The i-DRILL engineered drilling system design was used to model a custom BHA system and recommend drilling parameters to optimize the drilling process and mitigate shock and vibration. The BHA included a PowerDrive Xceed* 900 rotary steerable system (RSS), an MDi816 PDC drill bit from Smith Bits, a Schlumberger company, a Rhino XS* hydraulically expandable reamer, and WELL COMMANDER† ball activated drilling valve from M-I SWACO, a Schlumberger company.

After considering several different i-DRILL scenarios, the optimum drilling parameters were identified to preserve the bit and reamer cutting structure while keeping the surface torque below a 20,000-lbf.ft torque limit. Strict adherence to the recommended parameters was key to obtaining the desired directional drilling results, while mitigating the risk of shock-related failure.

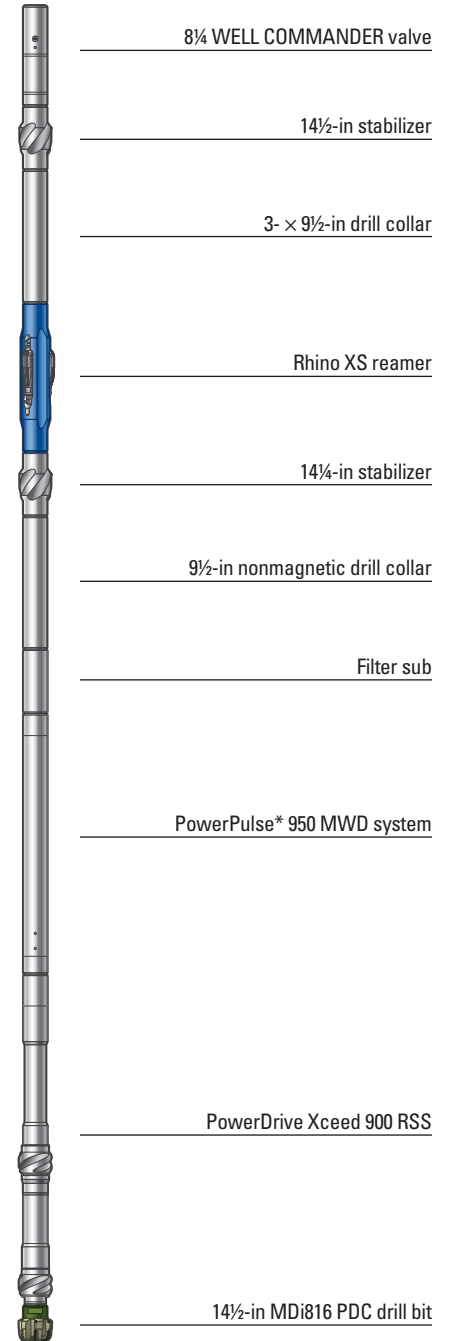

The i-DRILL engineered drilling system design was used to model a customized BHA to drill through the hard shale offshore formation.

CASE STUDY: Optimized BHA system and drilling parameters save 6 days in Persian Gulf

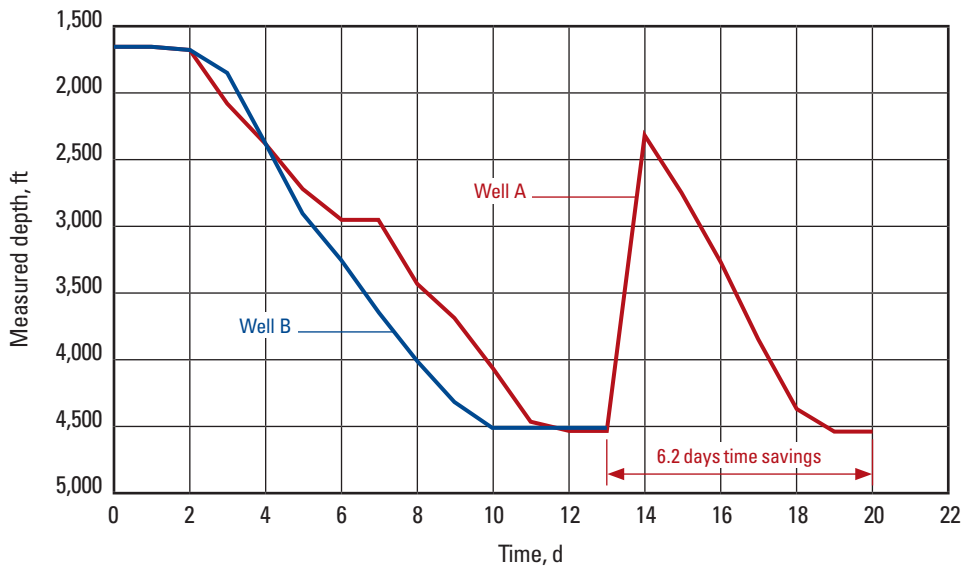

A comparison of the current well (Well B) with a previous offset well (Well A) shows a time savings of 6.2 days on Well B. Well A used a conventional steerable BHA to drill the section to TD, followed by a hole opening run that took 16.9 days to accomplish. For Well B, the same interval was drilled in 10.7 days.

Saved 6.2 days and USD 744,000

The BHA with an RSS and underreamer, which included a dedicated cleanout BHA for the rathole, drilled and underreamed the interval in less than 11 days for a total savings of 6.2 days and USD 744,000. Postrun analysis showed minimal damage to the cutting structure even after drilling through the hard Aruma shale.

Contact your local Schlumberger representative to learn more.

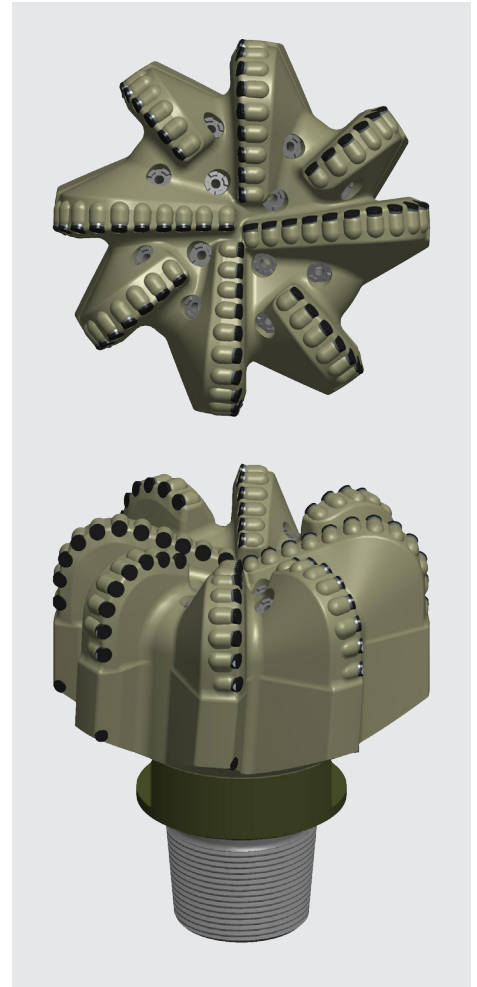

The BHA included an MDi816 PDC drill bit, which drilled through the hard shale with minimal damage to the cutting structure.

slb.com/drilling